

\* minimum stroke is 0.75" (20mm)  
\*\* minimum space between numbers is 0.40" (10mm)

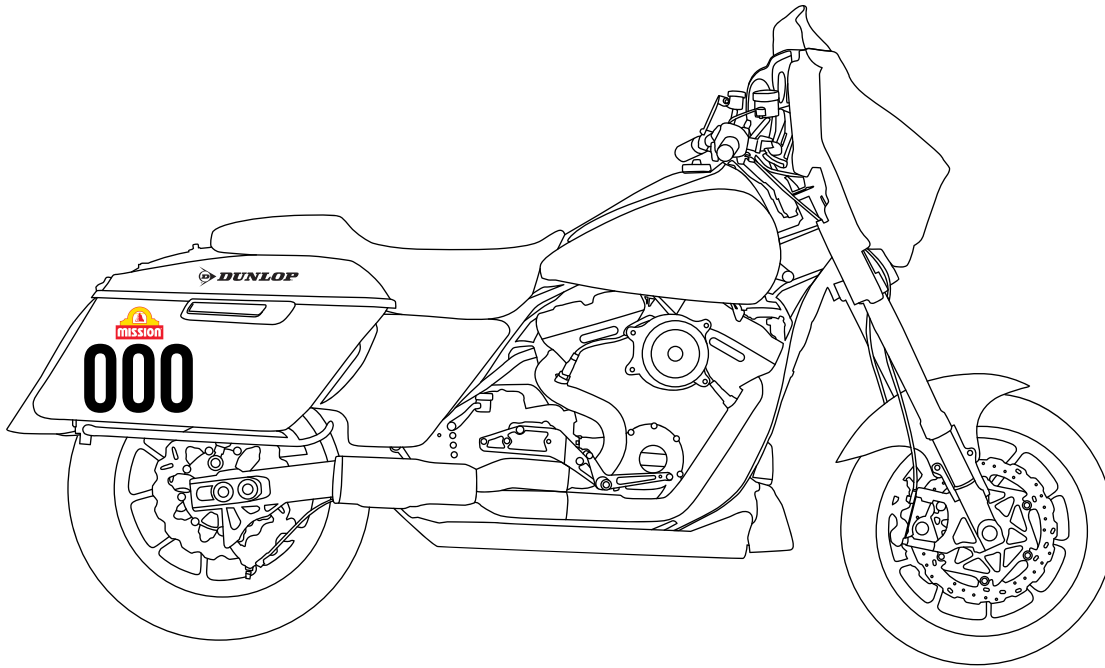

2.75" (70mm)  
minimum

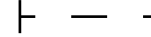

4.75" (120mm)  
minimum



000

\* minimum stroke is 0.75" (20mm)  
\*\* minimum space between numbers is 0.40" (10mm)

2.5" (63mm)  
minimum



4" (101mm)

5.5" (140mm)  
minimum

**D  
U  
N  
L  
O  
P**

1.67" (42mm)

2.5" (63mm)  
minimum



12" (305mm)

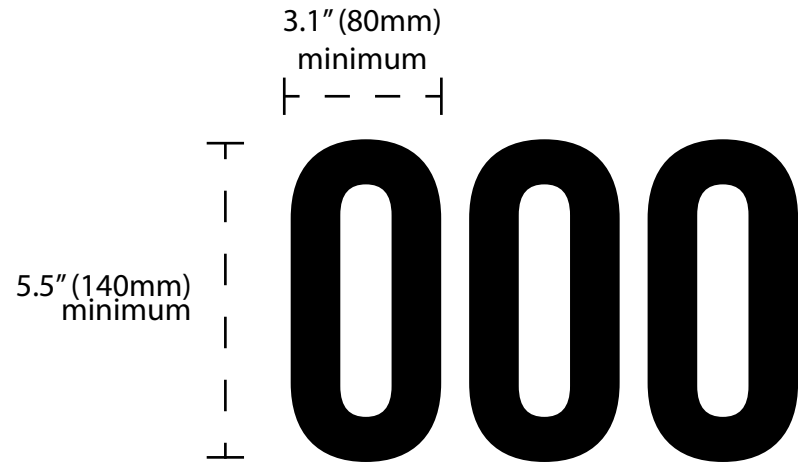
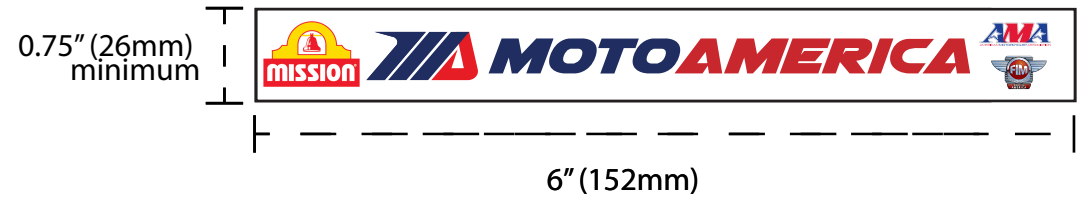
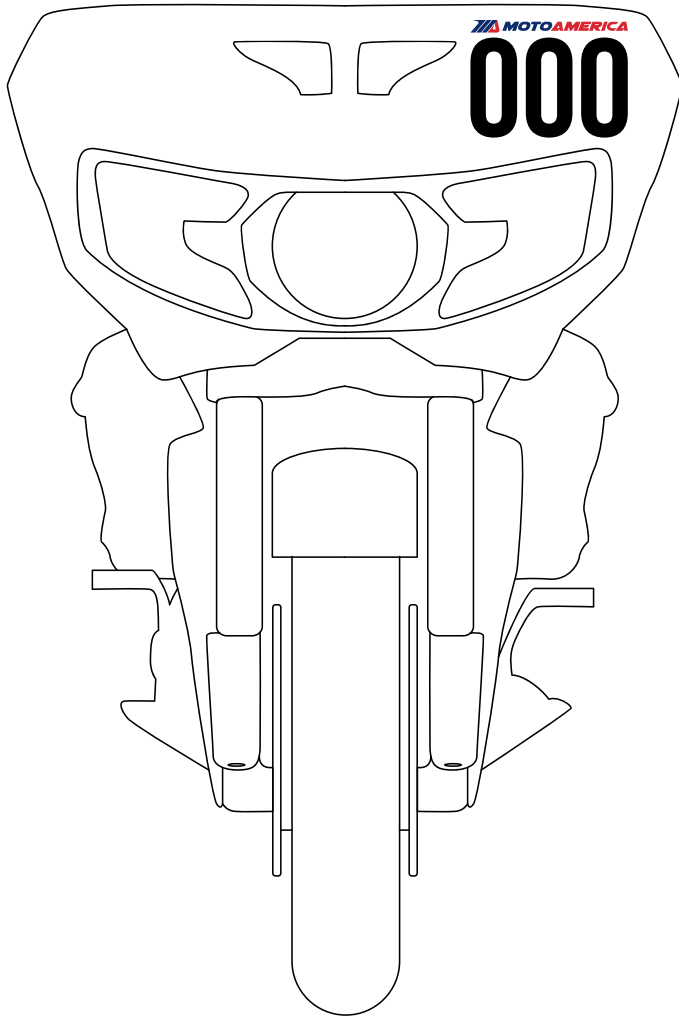

\* minimum stroke is 0.75" (20mm)  
\*\* minimum space between numbers is 0.40" (10mm)

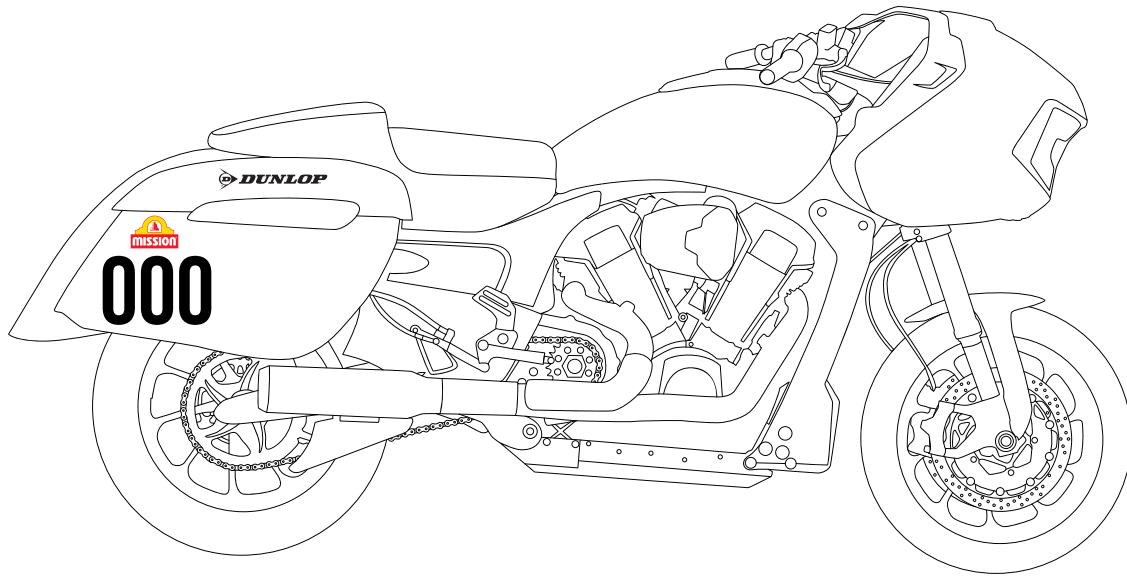

2.75" (70mm)  
minimum

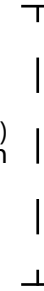
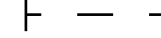

4.75" (120mm)  
minimum

000

\* minimum stroke is 0.75" (20mm)  
\*\* minimum space between numbers is 0.40" (10mm)

2.5" (63mm)  
minimum



4" (101mm)

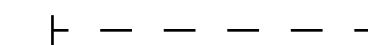

5.5" (140mm)  
minimum

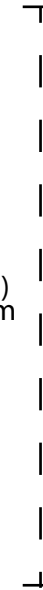

D  
U  
N  
L  
O  
P

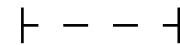

1.67" (42mm)

2.5" (63mm)  
minimum

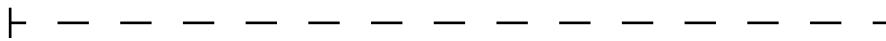

12" (305mm)



# RIDER SUIT

SERIES PARTNER: 4.5" X 1.7"

MOTOAMERICA: 4" X 2"

DUNLOP (FRONT) : 4.82" X 1"

DUNLOP (REAR): 10" X 2.03"

AMA/FIMNA: 5" X 1.22"

\*The series partner requirements will be released if required.  
All teams must leave this space available.

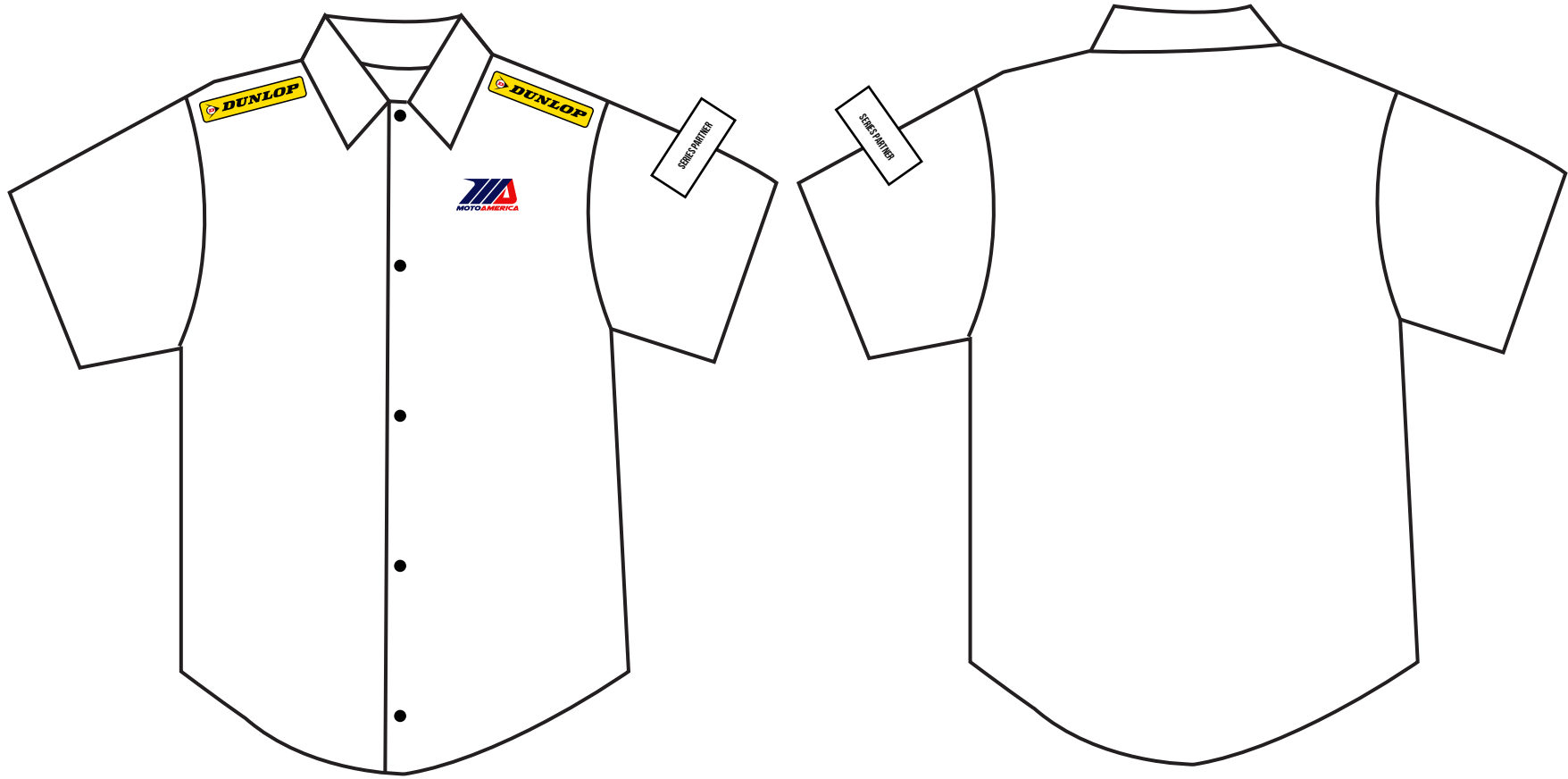

# TEAM SHIRT

LOGOS ARE REQUIRED FOR COMPETITION

+ SERIES PARTNER\*: 4.5"X1.75"

+ MOTOAMERICA SERIES LOGO 4"X2"

+ DUNLOP (FRONT): 4.82"X1"

\*The series partner requirements will be released if required.  
All teams must leave this space available.